

Humidity Bobcat™

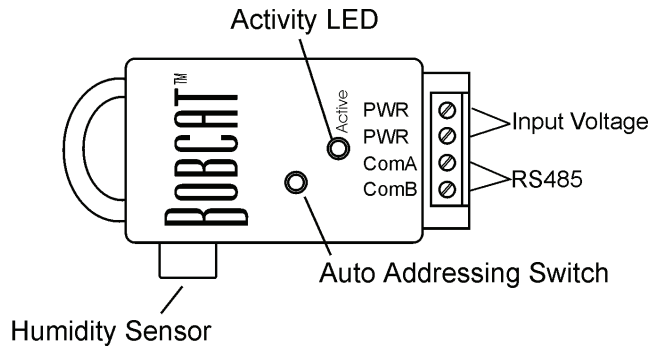

Introduction

The Humidity Bobcat™ is a single point module providing humidity readings from 5% to 95% RH.

Specifications

Power: Input Voltage 9 - 12V DC or AC
 Input Current Max 30mA

Dimensions: 1.3"W x 2.5"L x 0.6"D

Operating
 Temperature: 32°F to 158°F

Resolution: 1% RH ± 1%

Setup

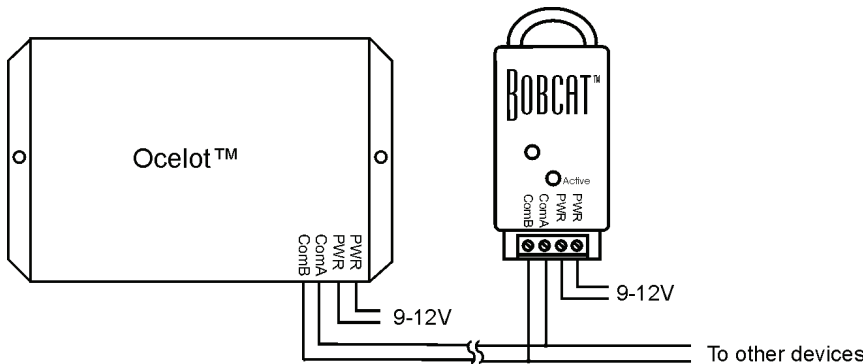

Figure 1. Typical Wiring Diagram

Note: The Bobcat™ may be used outdoors but must be installed in an area so that it will not get wet!

Operation

LED Codes

ON solid – Bobcat™ has not been addressed

Slow Blink – Bobcat™ has a valid address

Fast Blink – Auto address mode active

On solid, then Rapid blink - ADICON™ communications active

Parameter	Function
1	Module Address
5	Gain (do not change) – default 128
6	Positive Humidity Offset
7	Negative Humidity Offset

Table 1. Humidity Bobcat™ Parameters

The Humidity Bobcat™ is calibrated at the factory but small humidity adjustments may be made using parameters 6 and 7. Parameter 6 is used to increase the humidity reading by 1/4th of a percent increments and parameter 7 will reduce the reading by 1/4th of a percent increments. The maximum value for parameters 6 and 7 is 255 or 63.75 percent. Either parameter 6 or 7 should be 0. If both are non-zero then the value of parameter 7 will reduce the effect of parameter 6. For example, if parameter 6 is 20 (+ 5%) and parameter 7 is 8 (-2%) the humidity reading will only be increased by 3%.

Note: if your Bobcat has Version 2 software then the offset values will be in 1/16th percent increments and the maximum offset will be 15.9375 percent.

C-Max™ is used to change a parameter value. Below is a sample screen of the Module parameter utility. For more information about changing module parameters see the application note *Changing Module Parameters*.

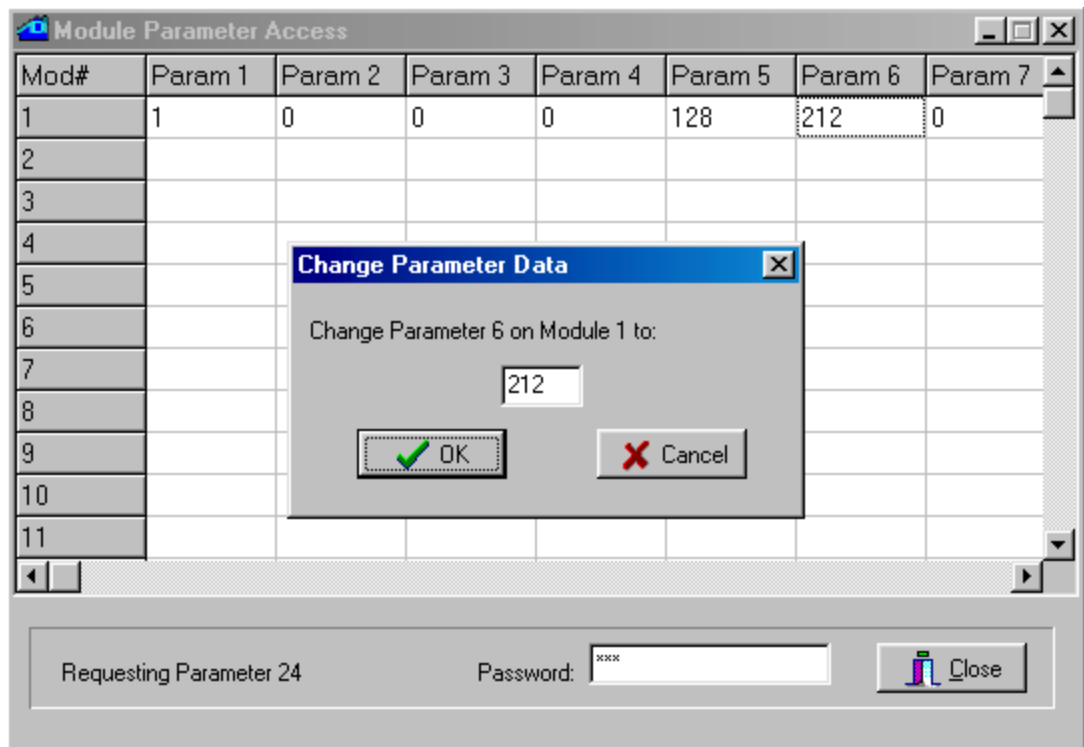

Viewing Bobcat™ data using C-MAX™

The CPUXA access screen of C-Max™ now has a data field to show the decimal value of data returned by a module. To view the data field, move the horizontal scroll bar all the way to the right. See the sample screen below. Data shown for a Bobcat™ module will be offset by 100, that is, the value shown is 100 greater than the actual data.

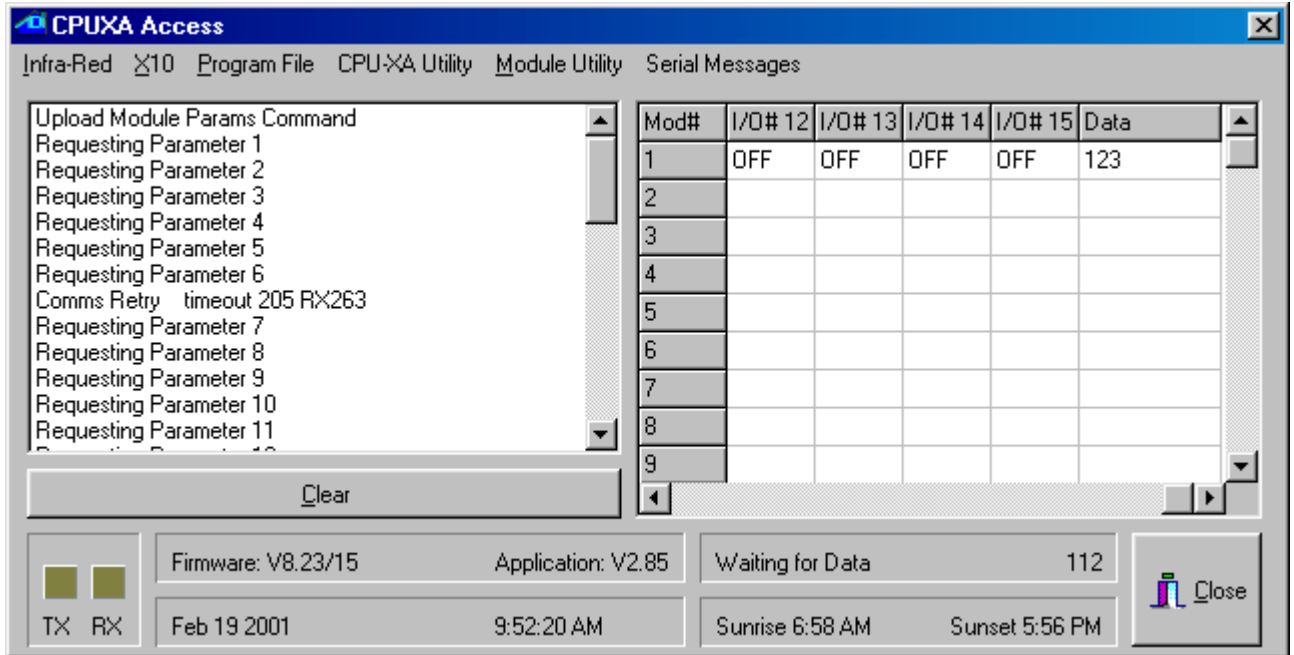

Accessing the Bobcat™ data

The following example shows how to turn on the humidifier if the humidity drops below 35%

Line#	Program Text	Comments
1	If Bobcat# 3 Data becomes < 35	If humidity drops below 35%
2	Then Module# 1/ Point# 1 Turns ON	Turn on the humidifier
3	End of Program	